

REVISIONS

DESCRIPTION	DATE (YR-MO-DA)	APPROVED
PRODUCT BASELINE		

NOTES:
 APPLICABLE STANDARDS/SPECIFICATIONS:
 A. ASME Y19.4 1995
 CALLOUTS IDENTIFIED ARE AS FOLLOWS:
 * NEW PARTS INCLUDED IN KIT
 # PARTS TO BE REMOVED AND DISCARDED
 Δ PARTS TO BE REMOVED AND REUSED
 ALL DIMENSIONS ARE IN INCHES
 PART OF SEATBELT ASSEMBLY 12480530

**INSTALLATION INSTRUCTIONS
 FOR NON-ARMOR THREE-POINT FRONT SEATBELT OPTION KIT**

SECTION I. INTRODUCTION

PURPOSE. THE PURPOSE OF THESE INSTRUCTIONS IS TO PROVIDE A PROCEDURE FOR INSTALLATION OF FRONT THREE-POINT SEATBELTS FOR NON-ARMOR M998, M998A1, M998A2, M1035, M1037, M1038, M1097, M1097A1, AND M1097A2 VEHICLES.

REV	---	---	---	---	---	---	---	---	---	---	---	---	---	---	---	---	---	---	---
SHEET	35	36	37	38	39	40	41	42	43	44									
REV	---	---	---	---	---	---	---	---	---	---	---	---	---	---	---	---	---	---	
SHEET	17	18	19	20	21	22	23	24	25	26	27	28	29	30	31	32	33	34	
REV STATUS OF SHEETS	REV	---	---	---	---	---	---	---	---	---	---	---	---	---	---	---	---	---	
	SHEET	1	2	3	4	5	6	7	8	9	10	11	12	13	14	15	16		

APPLICATION				AM GENERAL LLC ENGINEERING & TECHNICAL SERVICES DIV. LIVONIA, MICHIGAN				
TEXT ASSY	USED ON							
		DRAWN BY		DATE (YR-MO-DA)		INSTALLATION INSTRUCTIONS, FOR NON-ARMOR THREE-POINT FRONT SEATBELT OPTION KIT		
		CHECKER		ENGINEER				
0286	HMMWV	DRAWING APPROVAL		DESIGN APPROVAL				
						SIZE A	CAGE CODE 34623	6500187
		SCALE NONE		UNIT WT. _____				

MWO 9-232-280-35-2

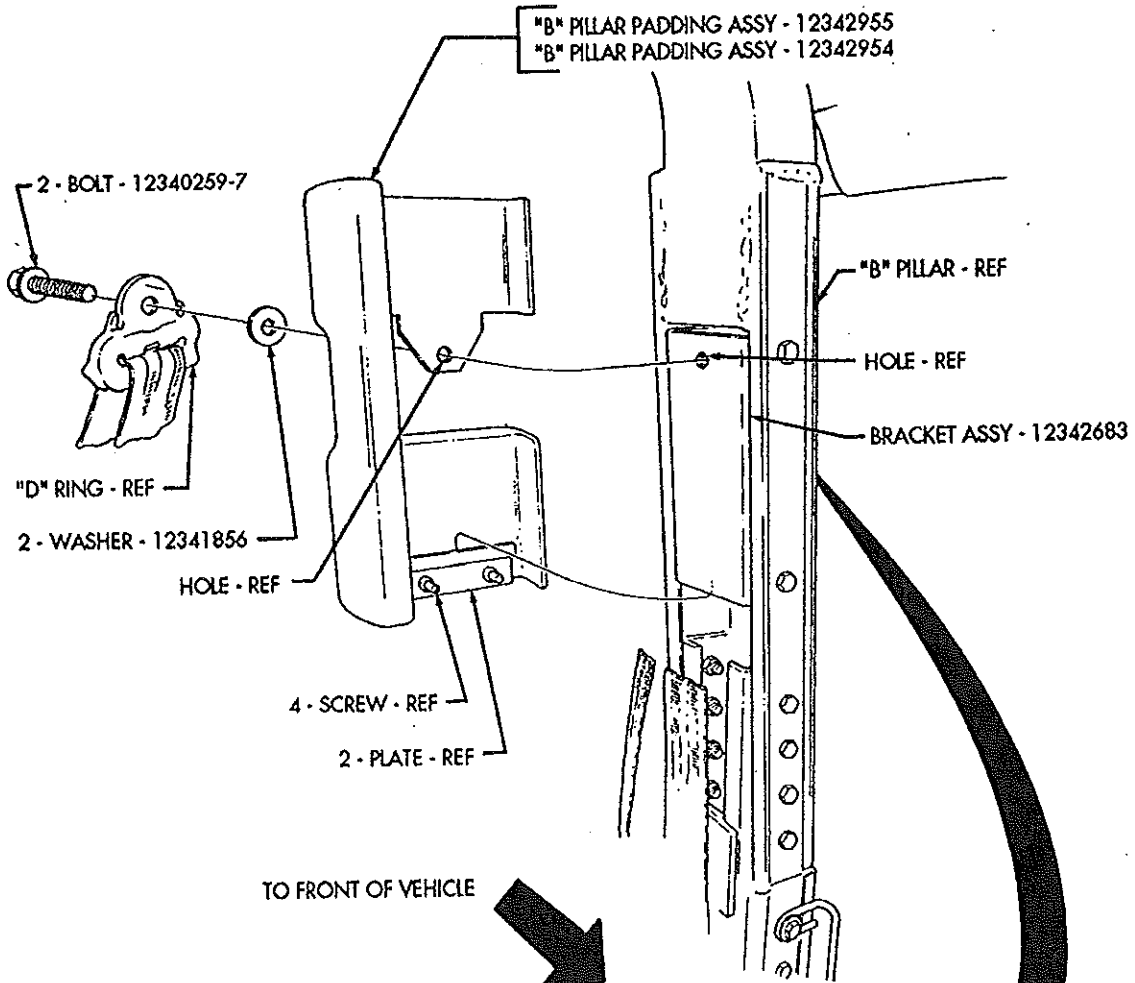

TO FRONT OF VEHICLE

(LEFT SIDE SHOWN, RIGHT SIDE OPPOSITE)

FIGURE 32

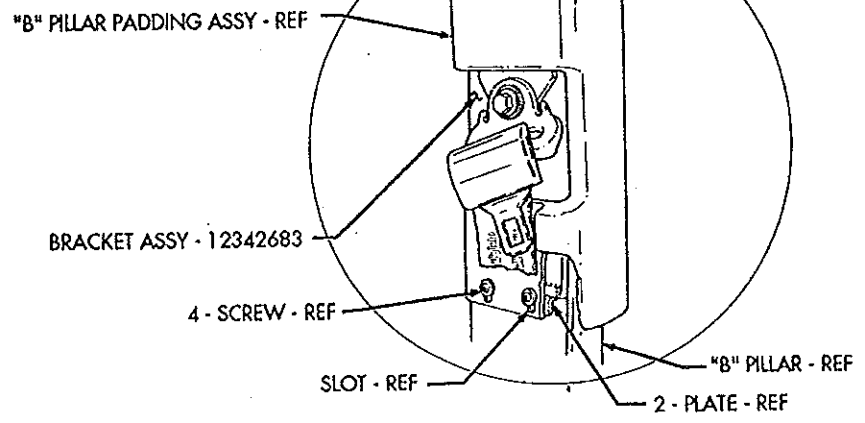

(LEFT SIDE SHOWN, RIGHT SIDE OPPOSITE)

FIGURE 32A

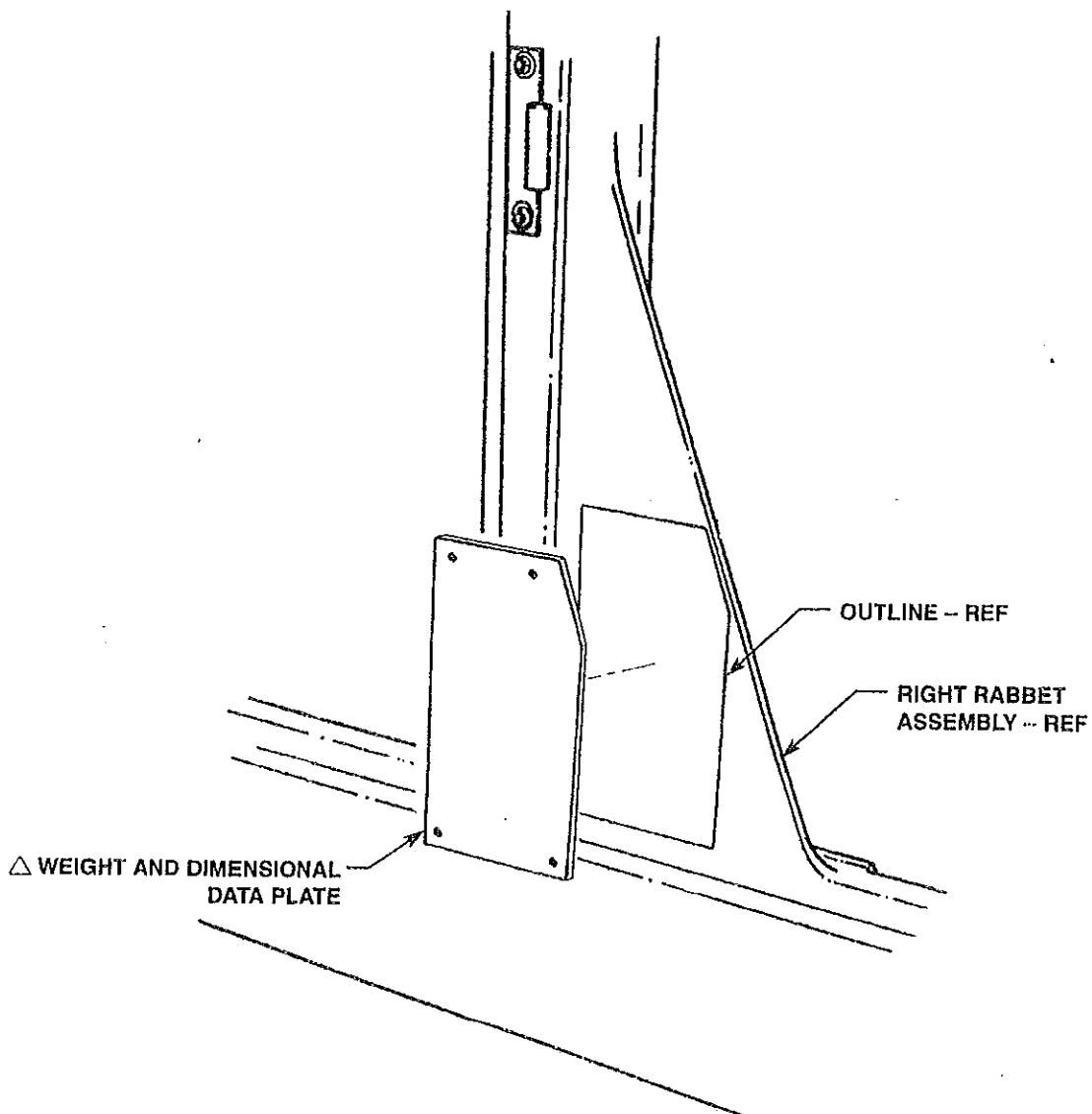
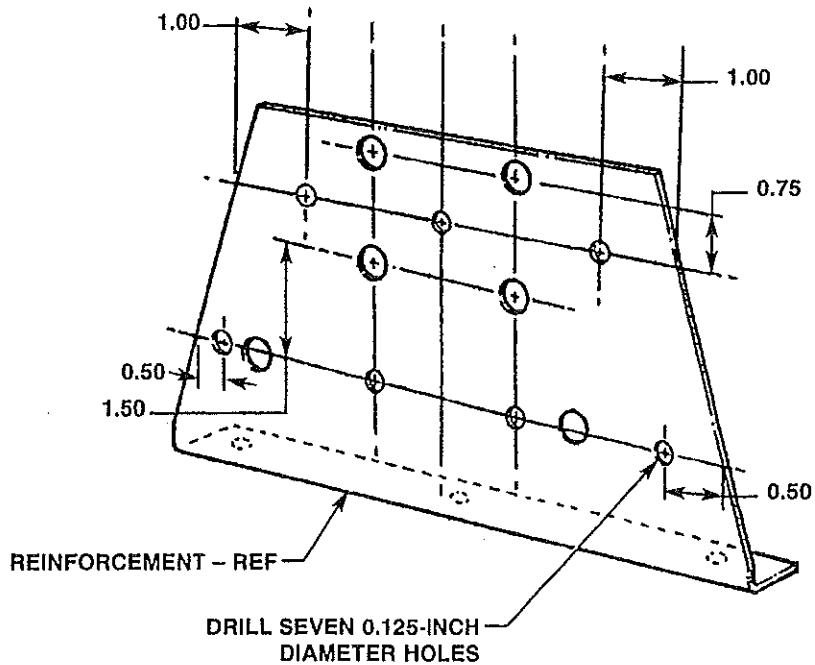

FIGURE 14

INSTALLATION INSTRUCTIONS, FOR NON-ARMOR THREE-POINT FRONT SEATBELT OPTION KIT	SIZE A	CAGE CODE 34623	6500187	
			REVISION LEVEL	—



LEFT SIDE SHOWN, RIGHT SIDE OPPOSITE

FIGURE 10

INSTALLATION INSTRUCTIONS, FOR NON-ARMOR THREE-POINT FRONT SEATBELT OPTION KIT	SIZE	CAGE CODE	6500187
	A	34623	
			REVISION LEVEL —

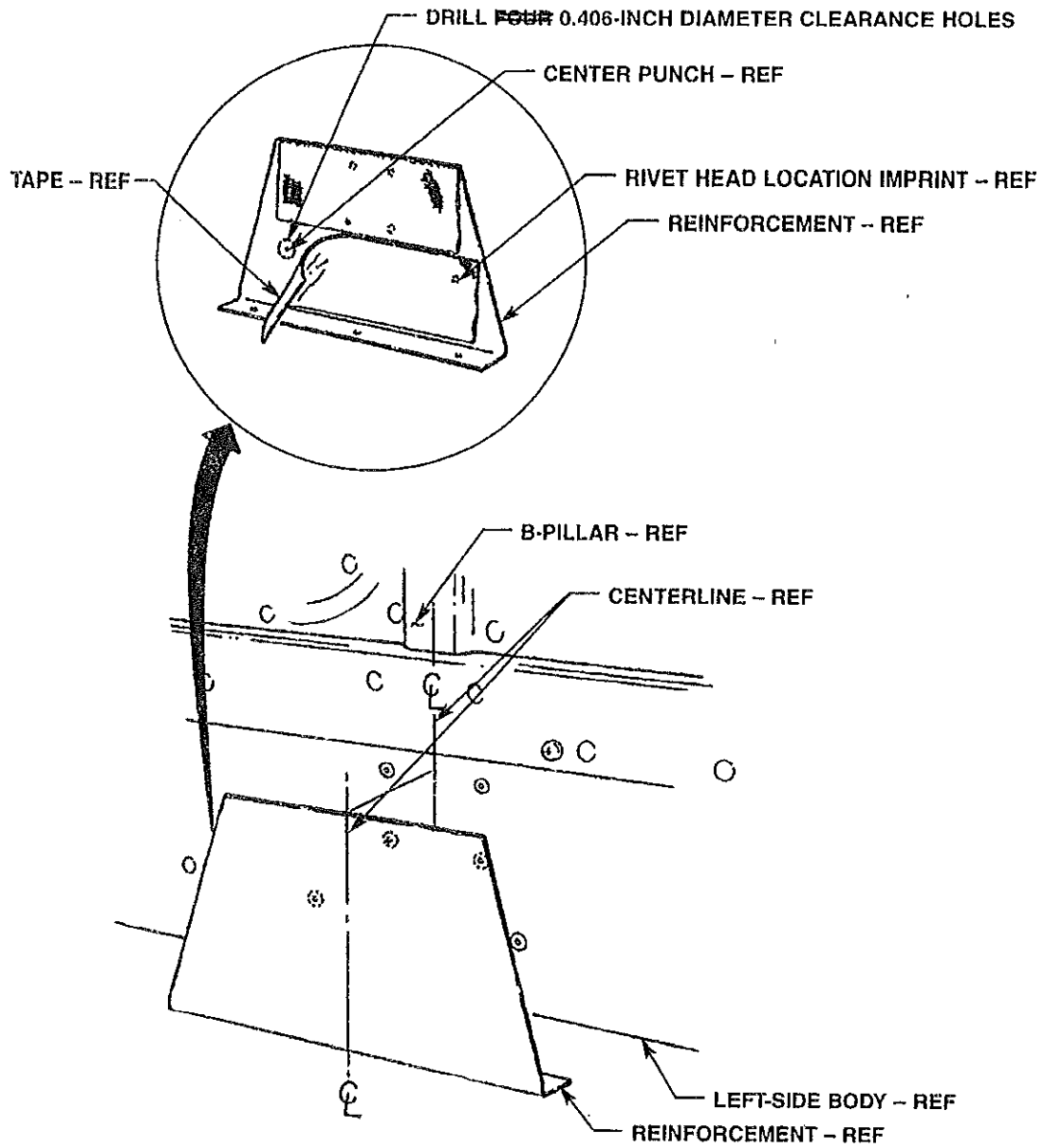

LEFT SIDE SHOWN, RIGHT SIDE OPPOSITE

FIGURE 9

INSTALLATION INSTRUCTIONS,
FOR NON-ARMOR
THREE-POINT FRONT SEATBELT
OPTION KIT

SIZE
A

CAGE CODE
34623

6500187

REVISION LEVEL —

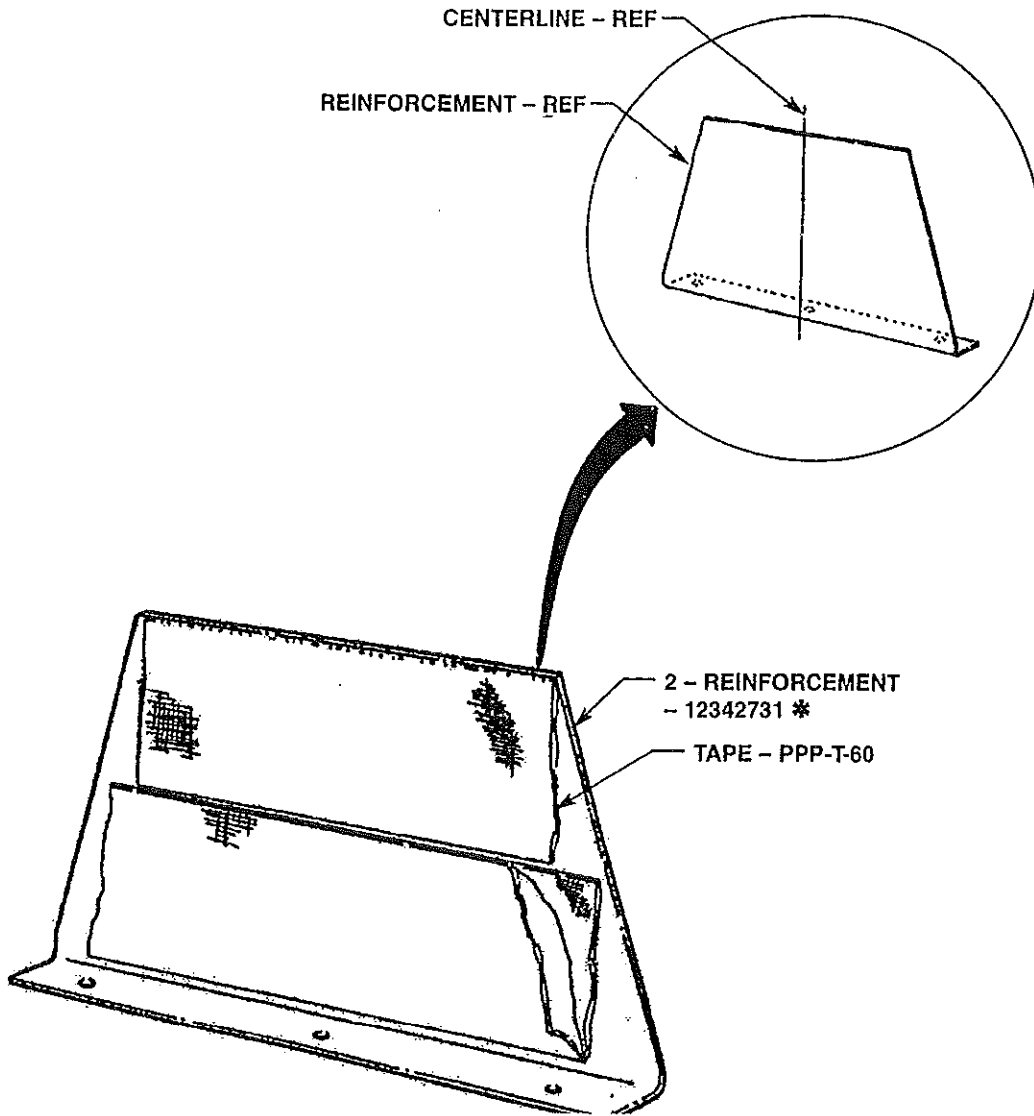

LEFT SIDE SHOWN, RIGHT SIDE OPPOSITE

FIGURE 8

**INSTALLATION INSTRUCTIONS,
FOR NON-ARMOR
THREE-POINT FRONT SEATBELT
OPTION KIT**

SIZE
A

CAGE CODE
34623

6500187

REVISION LEVEL ---

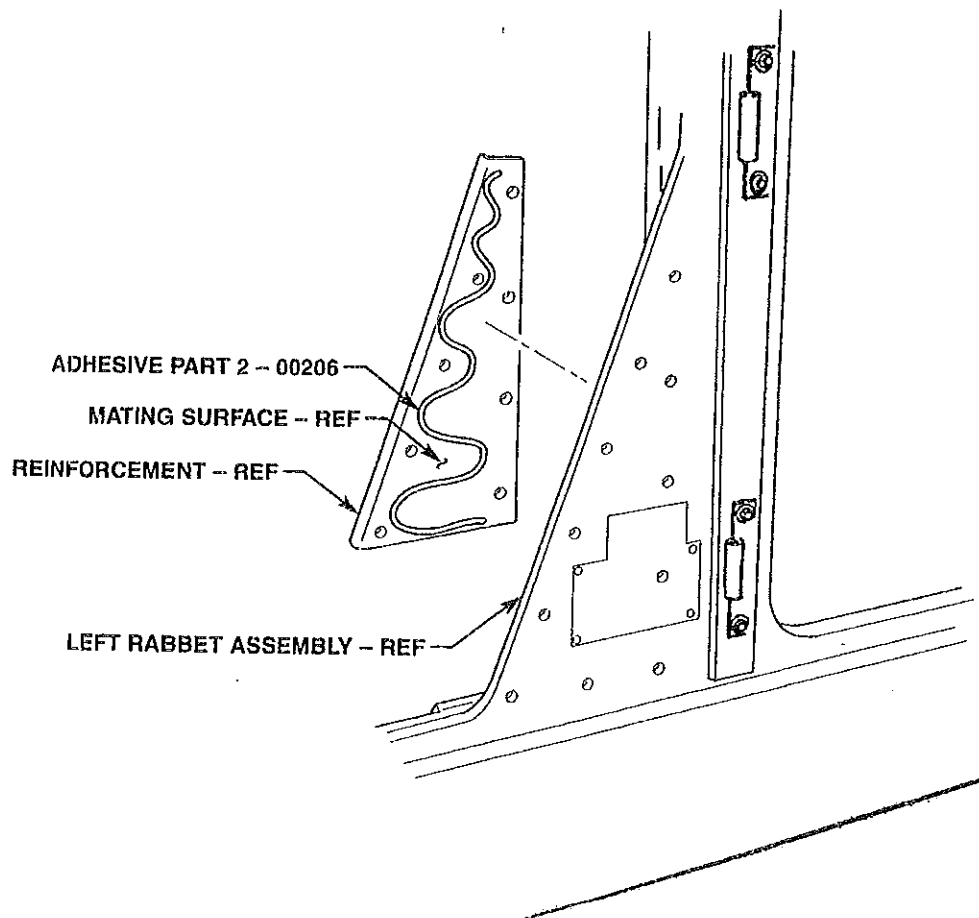

FIGURE 5

INSTALLATION INSTRUCTIONS, FOR NON-ARMOR THREE-POINT FRONT SEATBELT OPTION KIT	SIZE A	CAGE CODE 34623	6500187

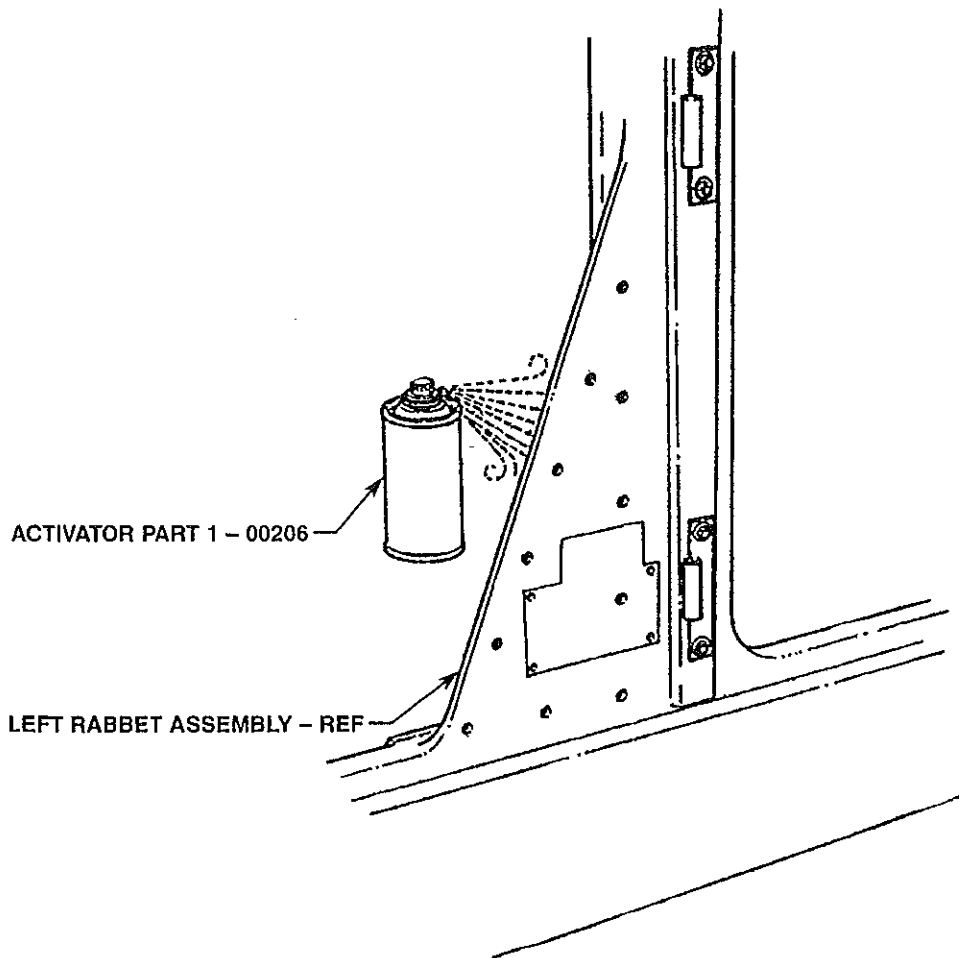

FIGURE 4

**INSTALLATION INSTRUCTIONS,
FOR NON-ARMOR
THREE-POINT FRONT SEATBELT
OPTION KIT**

SIZE

A

CAGE CODE

34623

6500187

REVISION LEVEL

—

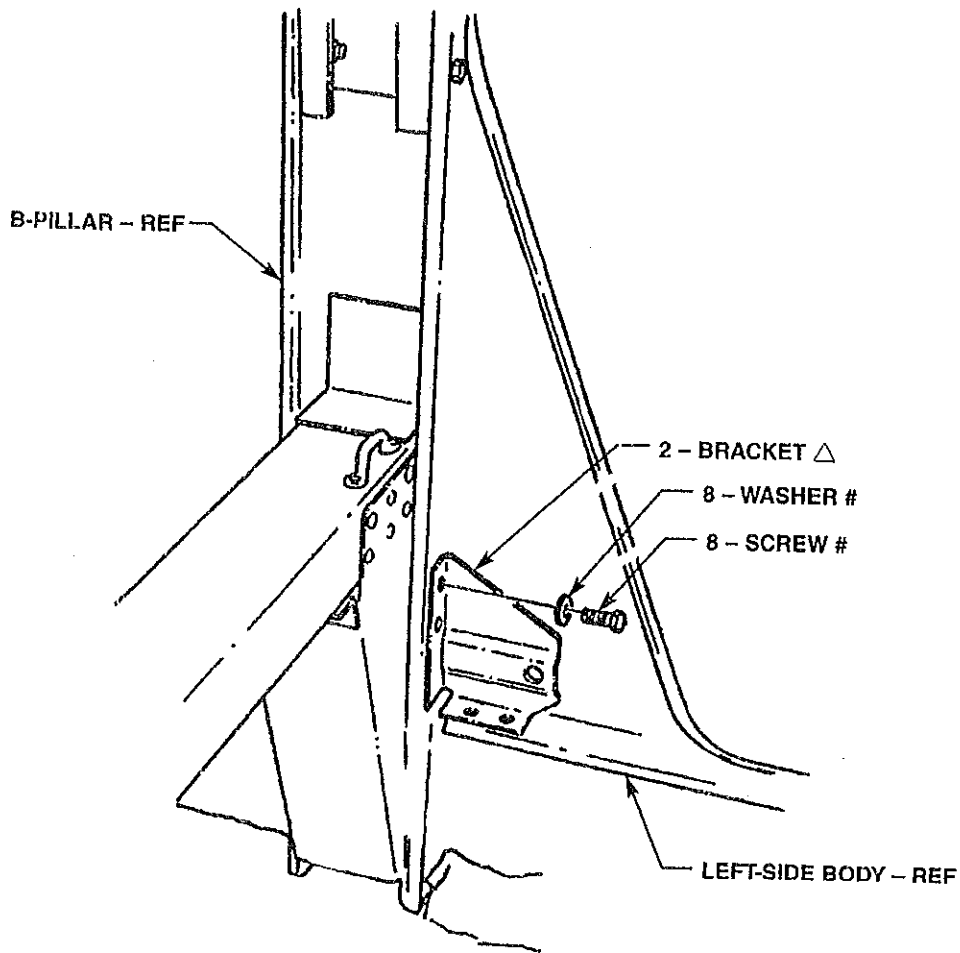

LEFT SIDE SHOWN, RIGHT SIDE OPPOSITE

FIGURE 2

INSTALLATION INSTRUCTIONS,
FOR NON-ARMOR
THREE-POINT FRONT SEATBELT
OPTION KIT

SIZE

A

CAGE CODE

34623

6500187

REVISION LEVEL ---

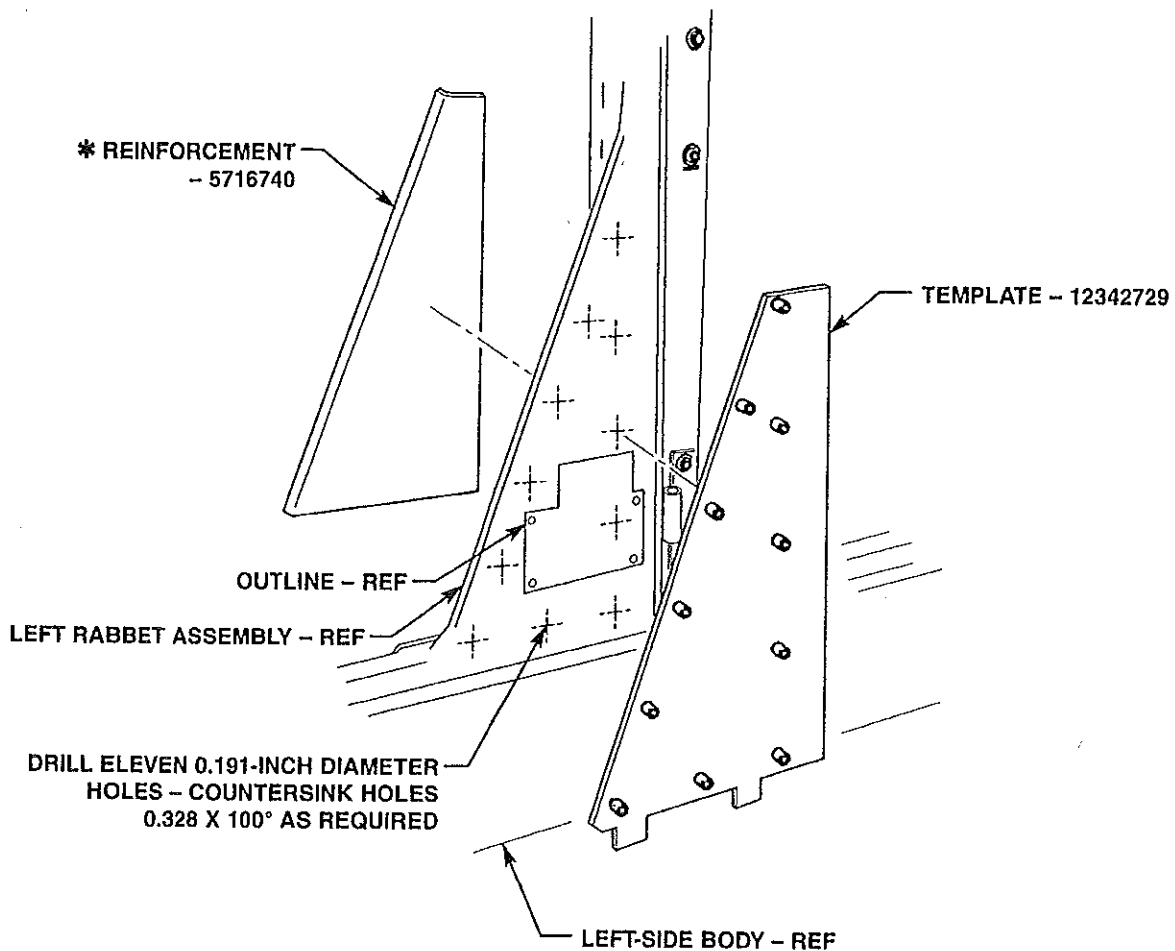
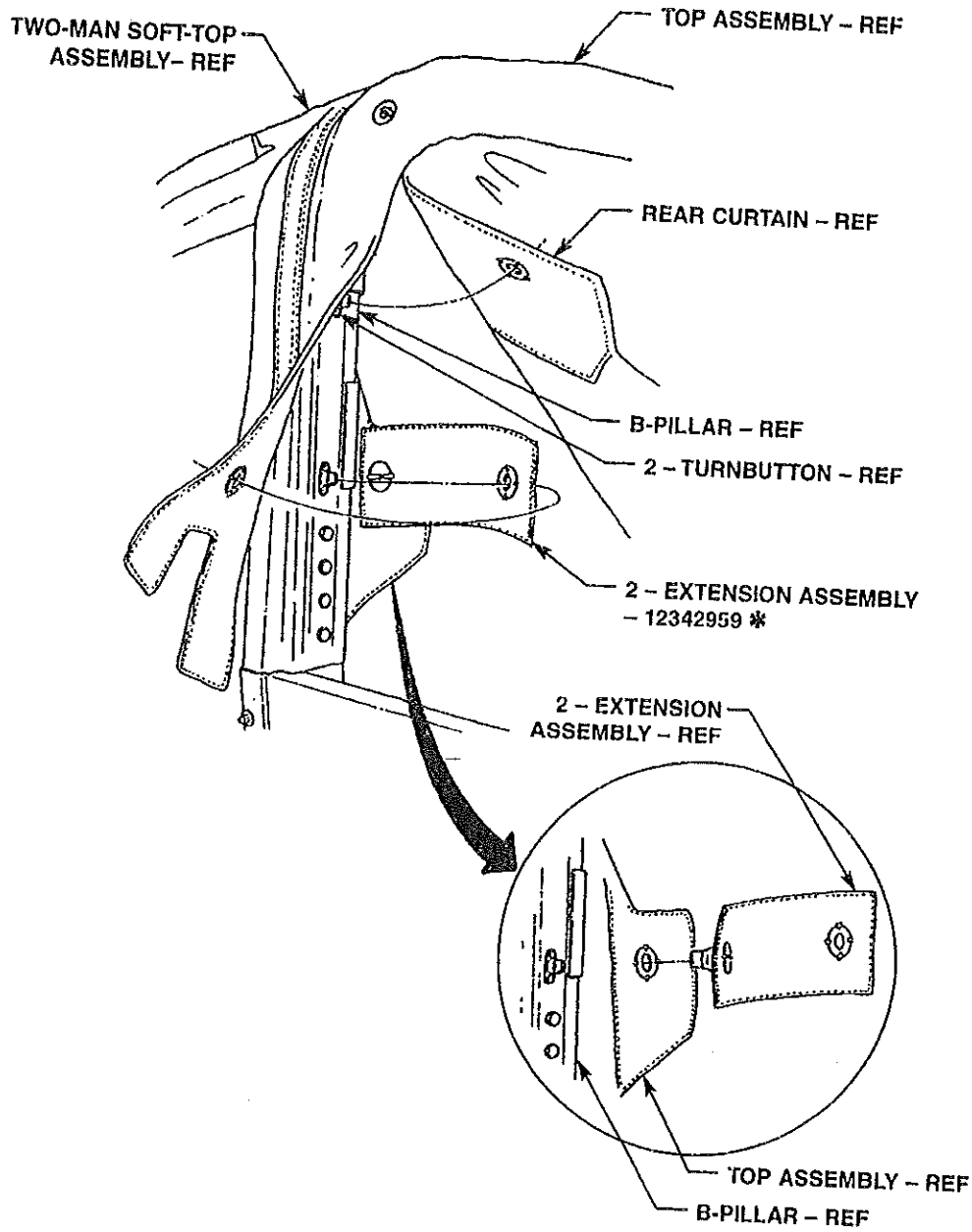

FIGURE 3

INSTALLATION INSTRUCTIONS, FOR NON-ARMOR THREE-POINT FRONT SEATBELT OPTION KIT	SIZE A	CAGE CODE 34623	6500187	
			REVISION LEVEL —	



LEFT SIDE SHOWN, RIGHT SIDE OPPOSITE

FIGURE 33

INSTALLATION INSTRUCTIONS,
FOR NON-ARMOR
THREE-POINT FRONT SEATBELT
OPTION KIT

SIZE
A

CAGE CODE
34623

6500187

REVISION LEVEL -

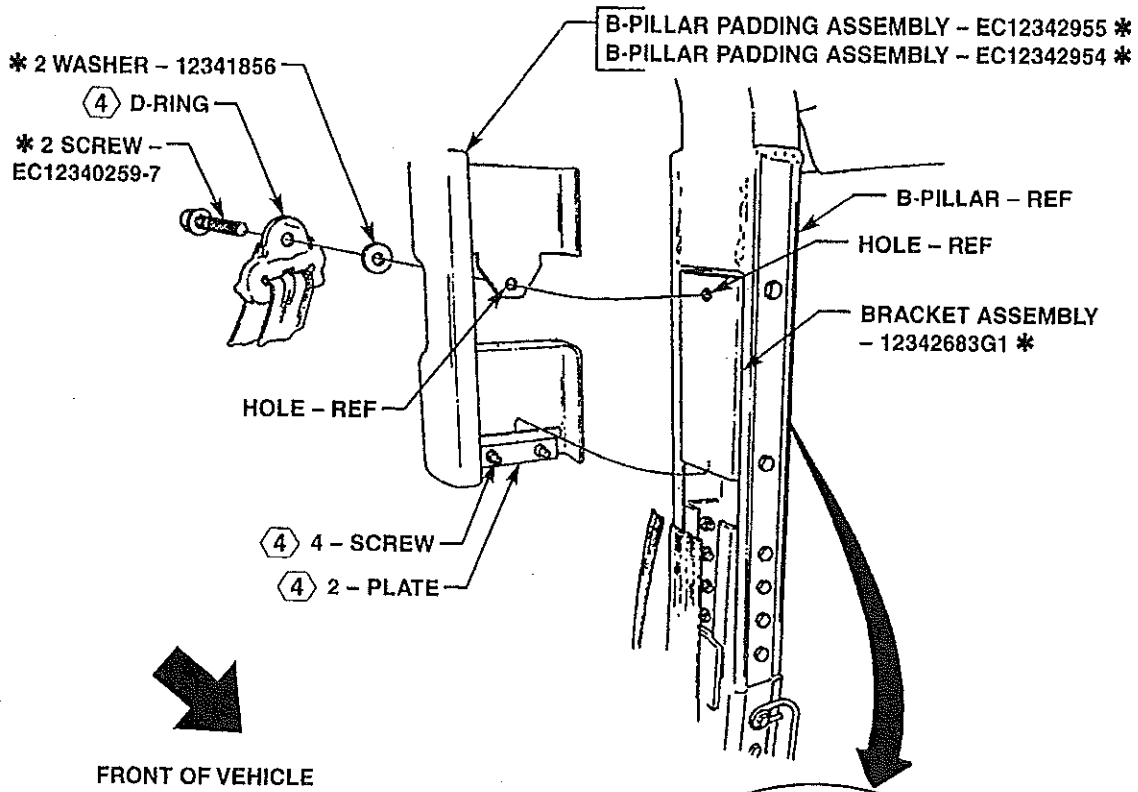

FRONT OF VEHICLE

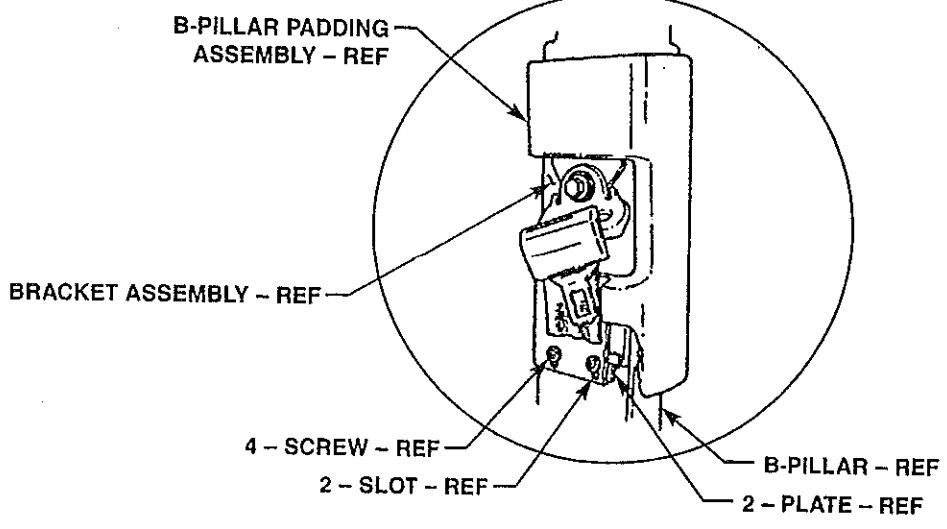

LEFT SIDE SHOWN, RIGHT SIDE OPPOSITE

FIGURE 32

INSTALLATION INSTRUCTIONS, FOR NON-ARMOR THREE-POINT FRONT SEATBELT OPTION KIT	SIZE A	CAGE CODE 34623	6500187
			REVISION LEVEL —

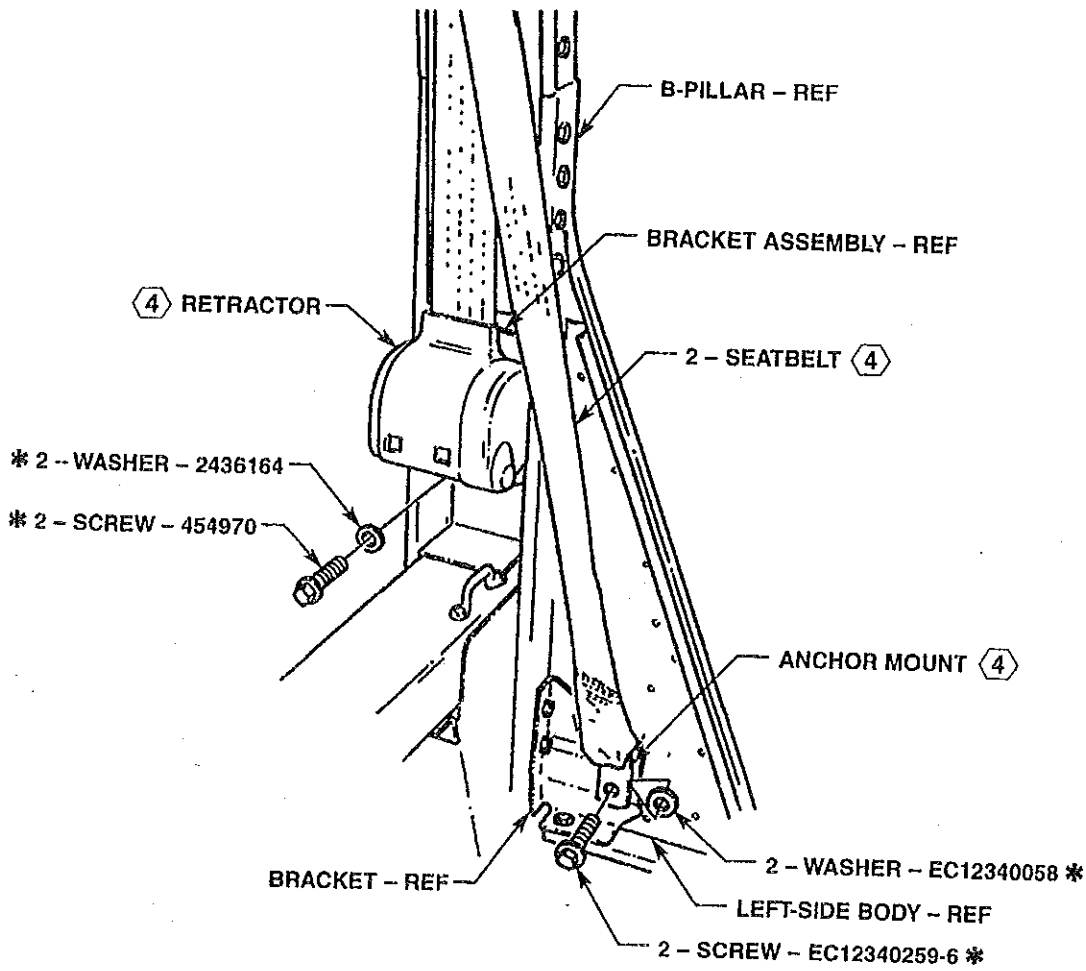

LEFT SIDE SHOWN, RIGHT SIDE OPPOSITE

FIGURE 31

INSTALLATION INSTRUCTIONS, FOR NON-ARMOR THREE-POINT FRONT SEATBELT OPTION KIT	SIZE A	CAGE CODE 34623	6500187
			REVISION LEVEL —

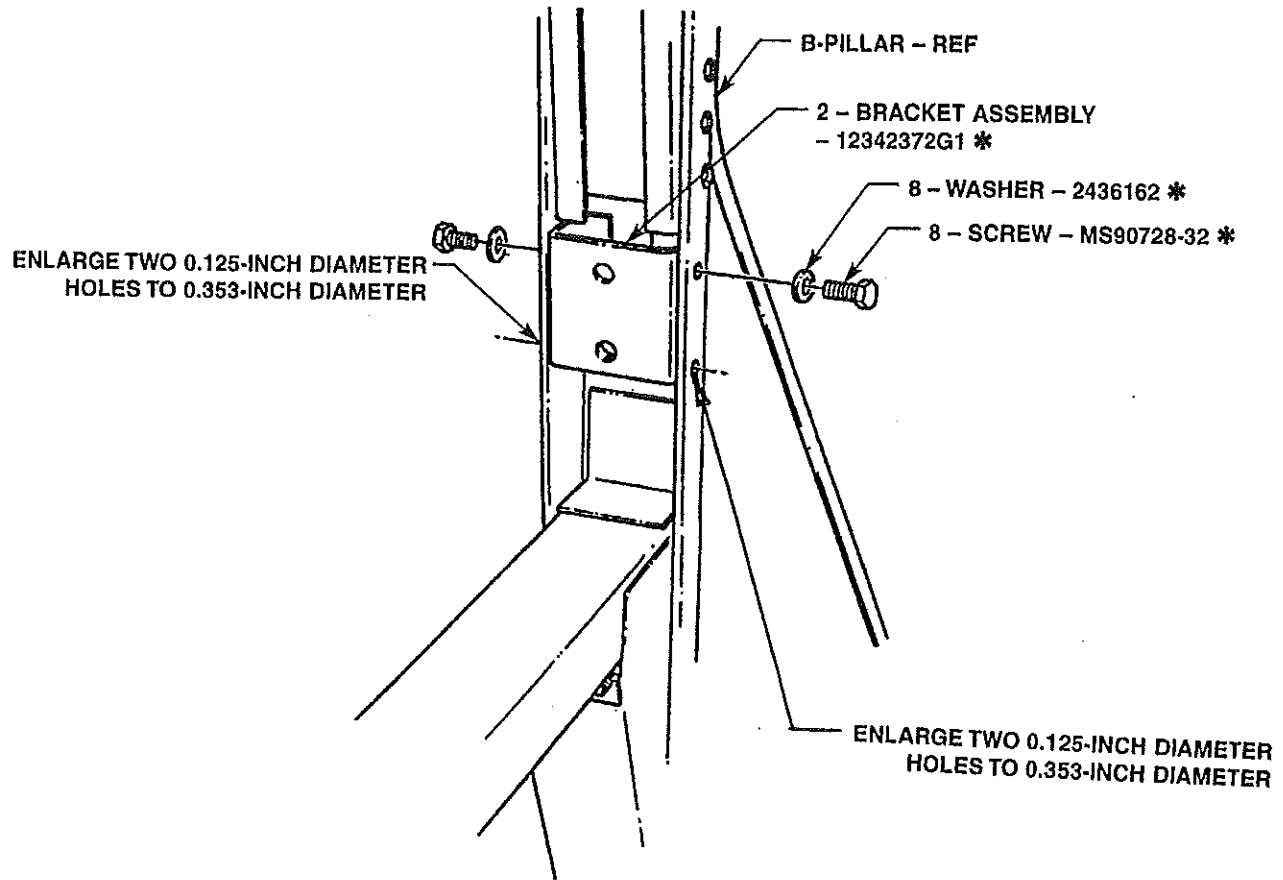

LEFT SIDE SHOWN, RIGHT SIDE OPPOSITE

FIGURE 30

INSTALLATION INSTRUCTIONS,
FOR NON-ARMOR
THREE-POINT FRONT SEATBELT
OPTION KIT

SIZE
A

CAGE CODE
34623

6500187

REVISION LEVEL —

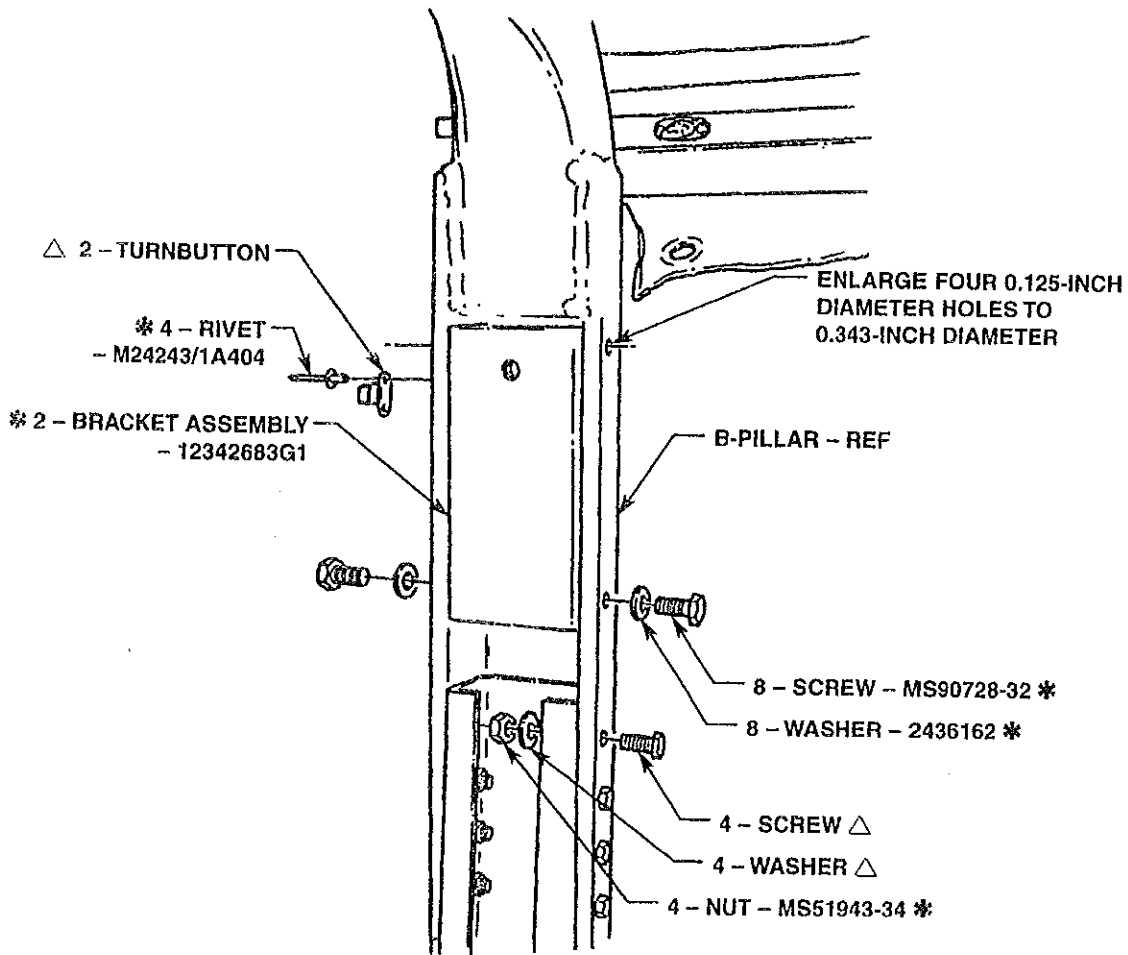

LEFT SIDE SHOWN, RIGHT SIDE OPPOSITE

FIGURE 28

INSTALLATION INSTRUCTIONS,
FOR NON-ARMOR
THREE-POINT FRONT SEATBELT
OPTION KIT

SIZE
A

CAGE CODE
34623

6500187

REVISION LEVEL —

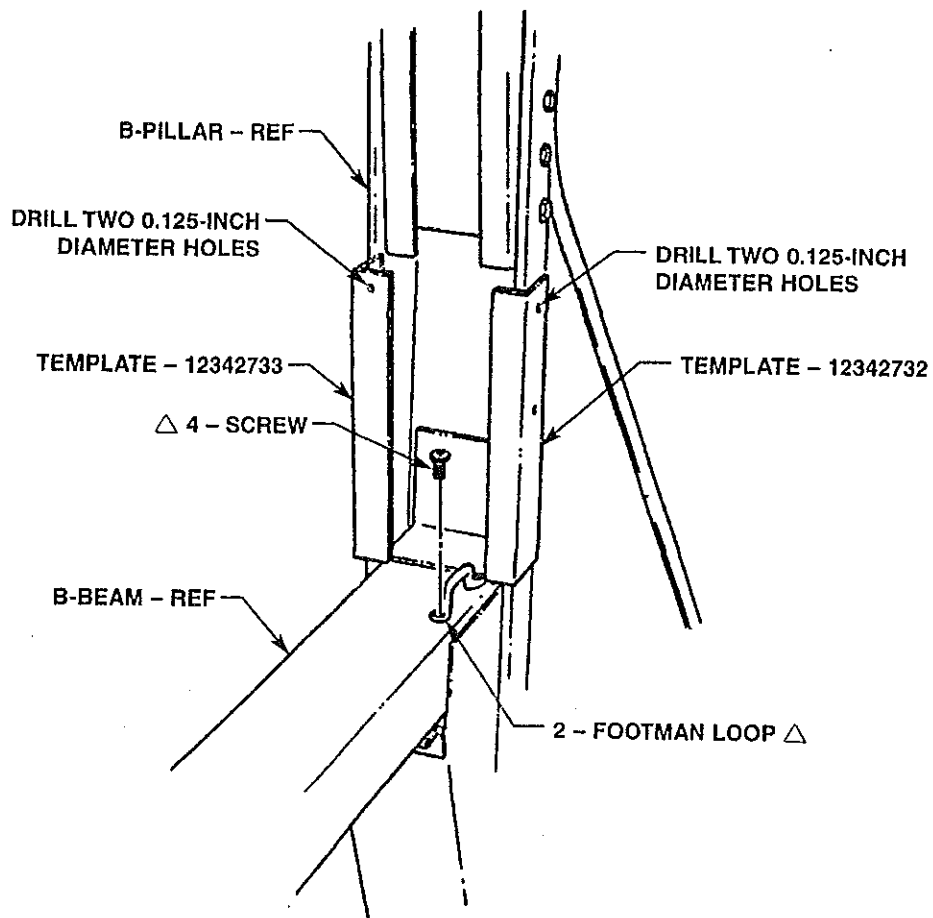

LEFT SIDE SHOWN, RIGHT SIDE OPPOSITE

FIGURE 29

INSTALLATION INSTRUCTIONS, FOR NON-ARMOR THREE-POINT FRONT SEATBELT OPTION KIT	SIZE A	CAGE CODE 34623	6500187
			REVISION LEVEL —

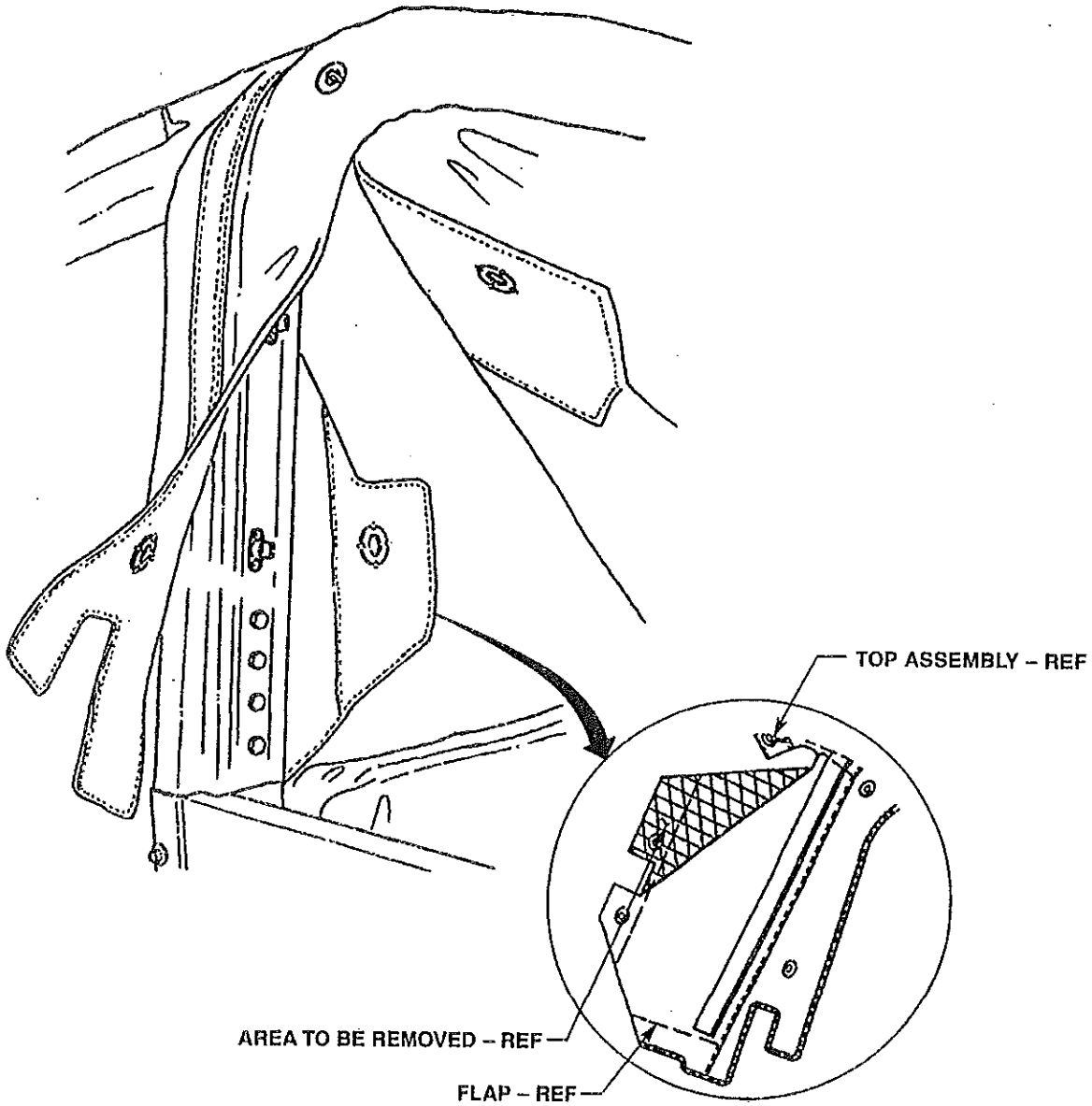

LEFT SIDE SHOWN, RIGHT SIDE OPPOSITE

FIGURE 26

INSTALLATION INSTRUCTIONS, FOR NON-ARMOR THREE-POINT FRONT SEATBELT OPTION KIT	SIZE A	CAGE CODE 34623	6500187	
			REVISION LEVEL	—

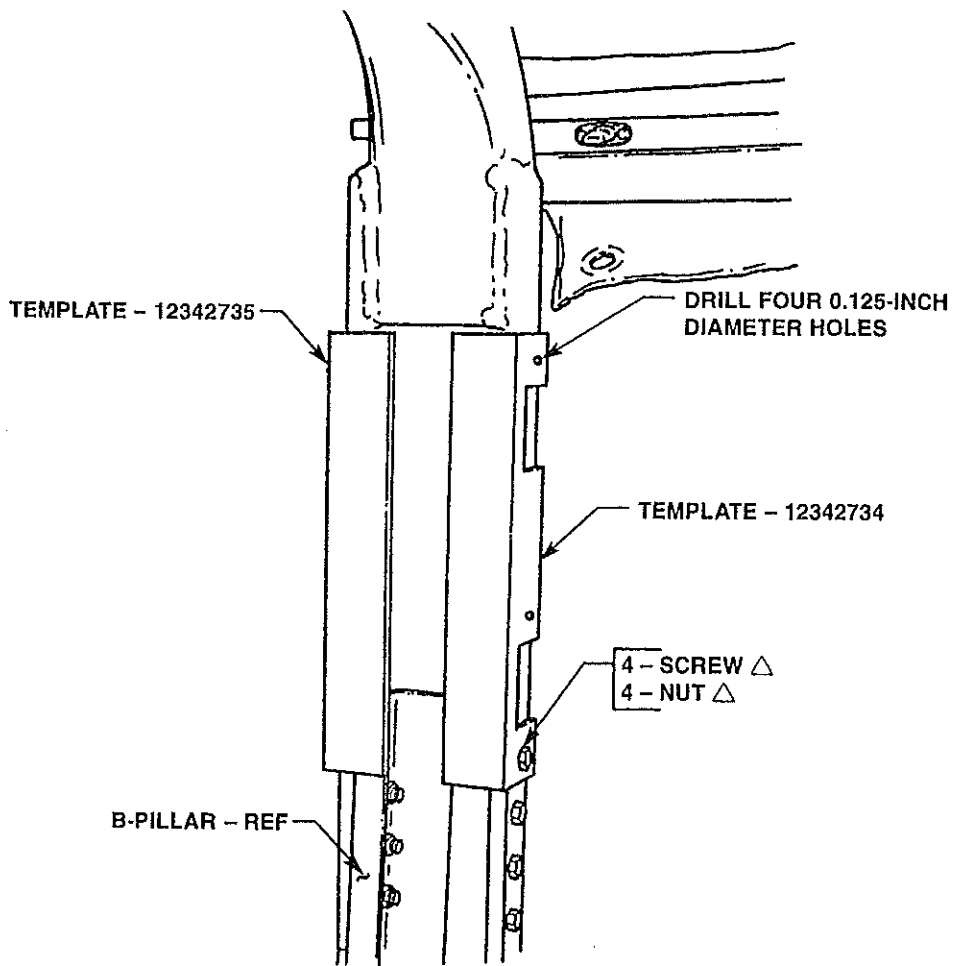

LEFT SIDE SHOWN, RIGHT SIDE OPPOSITE

FIGURE 27

INSTALLATION INSTRUCTIONS, FOR NON-ARMOR THREE-POINT FRONT SEATBELT OPTION KIT	SIZE A	CAGE CODE 34623	6500187

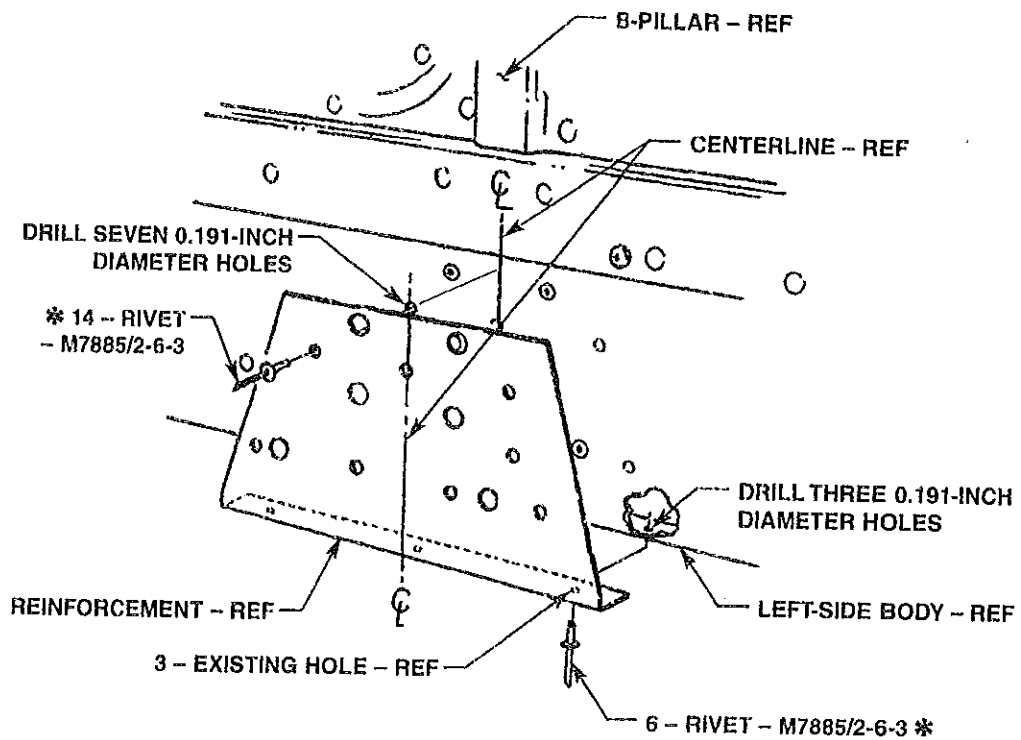

LEFT SIDE SHOWN, RIGHT SIDE OPPOSITE

FIGURE 11

INSTALLATION INSTRUCTIONS, FOR NON-ARMOR THREE-POINT FRONT SEATBELT OPTION KIT	SIZE A	CAGE CODE 34623	6500187
			REVISION LEVEL —

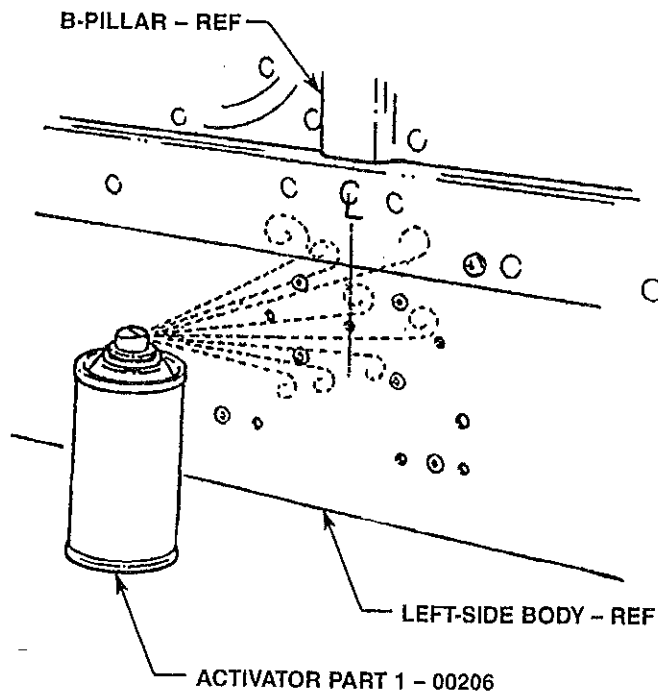

LEFT SIDE SHOWN, RIGHT SIDE OPPOSITE

FIGURE 12

INSTALLATION INSTRUCTIONS,
FOR NON-ARMOR
THREE-POINT FRONT SEATBELT
OPTION KIT

SIZE

A

CAGE CODE

34623

6500187

REVISION LEVEL

—